

## WLCSP33-9

**Package Code: CAA**

WLCSP33-9 (1.38mm x 1.38mm x 0.620mm)

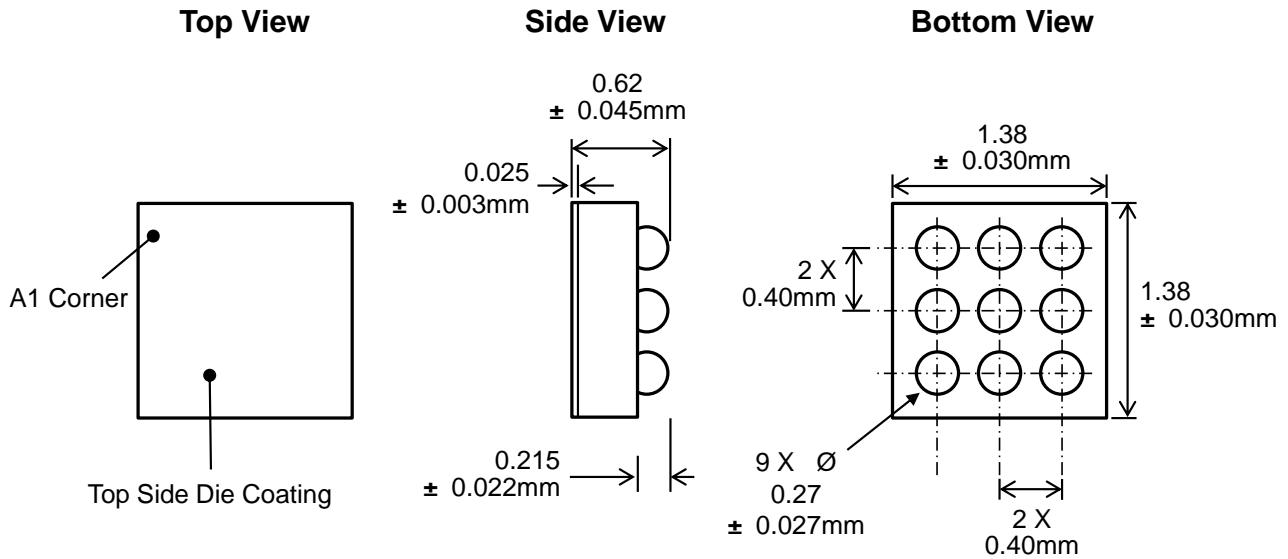

### Recommended Footprint

#### (NSMD Pad Type)

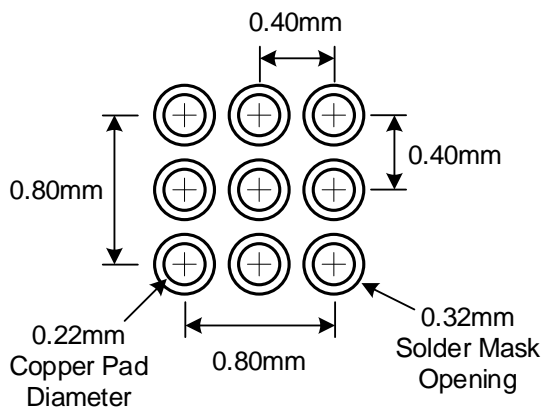

Kinetic Technologies cannot assume responsibility for use of any circuitry other than circuitry entirely embodied in a Kinetic Technologies product. No intellectual property or circuit patent licenses are implied. Kinetic Technologies reserves the right to change the circuitry and specifications without notice at any time.